

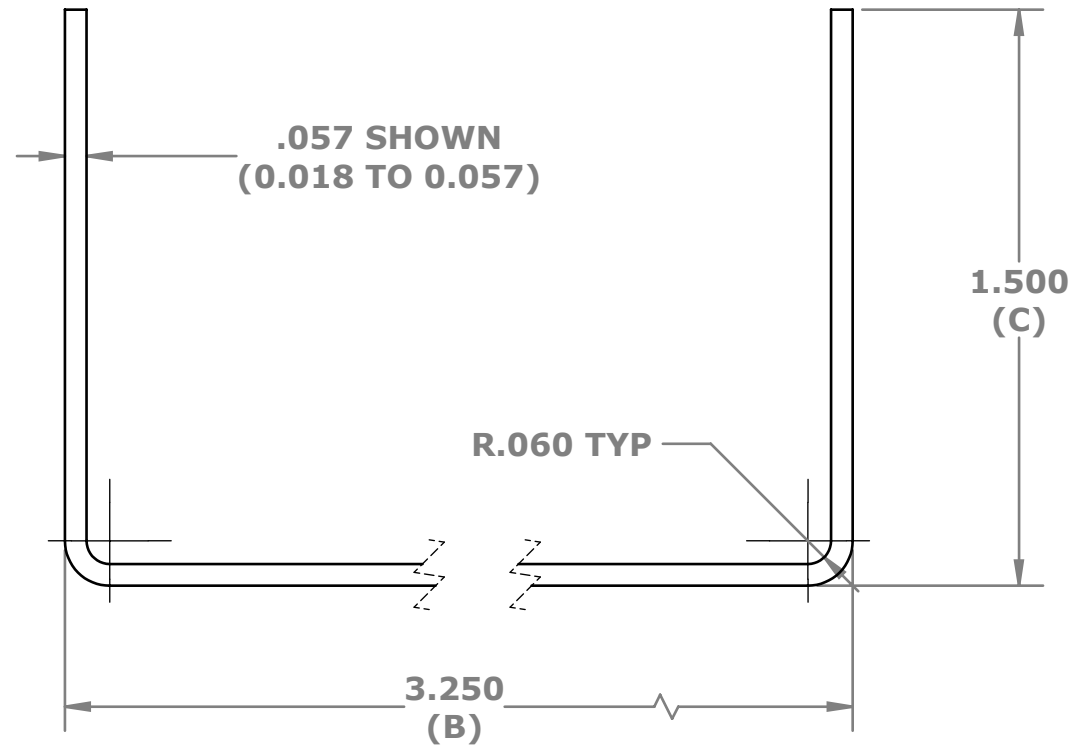

# 325U150

## [KFS-35C - #335C]

SFIA QC TOLERANCE - TRACK		
FEATURE	(REF)	TOLERANCE
LENGTH	(A)	+1/2, -1/4
WEB	(B)	+1/32 TO +1/8
FLANGE	(C)	+1/4, -1/16
FLARE	(E)	+0, -3/32
BOW	(F)	1/32 / FT - 1/2 MAX
CAMBER	(G)	1/32 / FT - 1/2 MAX
CROWN	(H)	+/- 1/16
TWIST	(I)	1/32 / FT - 1/2 MAX



STUD COIL SIZING - SHEET WIDTH - SHEET WEIGHT				
PROFILE	THEORETICAL	RECOMMENDED	MAXIMUM	WEIGHT (LB/FT)
150U050-54	2.311	2.38 TO 2.50	4.38	0.446
225U100-54	4.061	4.06 TO 4.19	5.25	0.784
325U150-54	6.061	6.06 TO 6.19	6.25	1.170